



Technical Report

C/23221/T01c

Supersedes C/23321/T01a dated 27 June 2016

Project

The Laboratory Measurement of Airborne Sound Insulation of a plasterboard partition sealed with SikaHyflex-250 Facade sealant

Prepared for

Sika Services AG

By

Richard Calvert

Published

28 July 2016

Quality Assurance

Project Title	The Laboratory Measurement of Airborne Sound Insulation of a plasterboard partition sealed with SikaHyflex-250 Facade sealant
Document Title	Technical Report
Client	Sika Services AG
Client Address	Sika Services AG Tuffenwies 16 8048 Zurich Switzerland
Author	Richard Calvert
Checker	Richard Critchlow
Report Number	C/23221/T01c
	Supersedes C/23221/T01b dated 27 June 2016

Summary

A test was done in SRL's Laboratory at Holbrook House, Sudbury, Suffolk, to determine the sound reduction index of a plasterboard partition sealed with SikaHyflex-250 Facade sealant in accordance with BS EN ISO 10140-2:2010.

From these measurements the required results have been derived and are presented in both tabular and graphic form in Data Sheets 1 and 2.

The results are given in 1/3rd octave bands over the frequency range 50Hz to 10kHz, which is beyond that required by the test standard. Measurements outside the standard frequency range are not UKAS accredited.



Richard Calvert
For and on behalf of
SRL Technical Services Limited
Tel: 01787 247595
Email: rcalvert@srltsl.com



Richard Critchlow
Deputy Technical Manager

Contents

Summary.....	3
1.0 Details of Measurements.....	5
2.0 Description of Test.....	8
3.0 Results.....	9
Data Sheets 1 and 2.....	12
Drawing 1.....	12
Drawing 2.....	13
Appendix A – Test Procedure.....	14
Appendix B – Measurement Uncertainty.....	16

1.0 Details of Measurements

1.1 Location

Sound Research Laboratories
Holbrook House
Little Waldingfield
Sudbury
Suffolk
CO10 0TF

1.2 Test Dates

18 & 23 December 2015

1.3 Tester

Allen Smalls and Richard Calvert of SRL Technical Services Limited

1.4 Instrumentation and Apparatus Used

Make	Description	Type
E D I	Microphone Multiplexer Microphone Power Supply Unit	
Norwegian Electronics	Real Time Analyser	830
Brüel & Kjaer	12mm Condenser Microphones Windshields Pre Amplifiers Microphone Calibrator Omnipower Sound Source	4166 UA0237 2639, 2669C 4231 4296
Larson Davis	12mm Condenser Microphone	2560
Douglas Curtis	Rotating Microphone Boom	
Oregon Scientific	Temperature & Humidity & Probe	THGR810
TOA	Graphic Equalizer	E-1231
QSC Audio	Power Amplifier	RMX 1450

1.5 References

- | | |
|------------------------|---|
| BS EN ISO 717-1:2013 | Rating of sound insulation in buildings and of building elements. Airborne Sound Insulation. |
| BS EN ISO 10140-2:2010 | Laboratory measurement of sound insulation for building element – Part 2: Measurement of airborne sound insulation. |

2.0 Description of Test

2.1 Description of Sample

Test 2 An unsealed partition of one layer of 12.5mm Knauf Wallboard Plasterboard each side of 100mm x 50mm timber studwork, 100mm insulation in stud work, with two “straight through” gaps 1.2m high by 20mm wide, and unsealed perimeter. See drawing 1 for details.

Test 4 As test 2, partition sealed at perimeter both sides and both “straight through” gaps sealed both sides with SikaHyflex-250 Facade sealant. See drawing 2 for details.

Sampling plan: Enough for test only

Sample condition: New

Details supplied by: SRL Technical Services and Sika Services AG

Sample installed by: SRL Technical Services and Sika Services AG

2.2 Sample Delivery date

18 December 2015

2.3 Test Procedures

The sample was mounted/located and tested in accordance with the relevant standard. The method and procedure is described in Appendix A. The measurement uncertainty is given in Appendix B.

3.0 Results

The results of the measurements and subsequent analysis are given in Data Sheets 1 and 2 and summarised below.

Results relate only to the items tested.

SRL Test No.	Description in Brief	$R_w (C;C_{tr})$
2	Partition unsealed	14 (0;0)dB
4	Partition sealed with SikaHyflex-250 Facade sealant	42 (-1;-6) dB

Data Sheet 1

Test Number :	2	Test Room:	Source	Receiving
Client:	Sika Services AG	Air temperature:	12.7 °C	13.8 °C
Test Date:	18/12/2015	Air humidity:	81 %	73 %
Sample height:	1.2 m	Volume:	55 m3	300 m3
Sample width:	2 m			
Sample weight:	17 kg/m2	Air Pressure:	1011 mbar	
Product	Partition - Unsealed			
Identification:				

Freq f Hz	Sound Reduction Index, dB	
	1/3 Oct	1/1 Oct
50+	13.2	13.3
63+	14.8	
80+	12.4	
100	13.0	15.5
125	18.5	
160	16.9	
200	18.3	18.5
250	19.1	
315	18.2	
400	19.4	18.9
500	19.3	
630	18.1	
800	16.8	13.1
1000	12.8	
1250	11.3	
1600	13.0	13.2
2000	13.4	
2500	13.3	
3150	14.2	15.1
4000	15.2	
5000	15.9	
6300+	17.1	17.8
8000+	17.9	
10000+	18.7	
Average 100-3150	16.0	Version v2.1

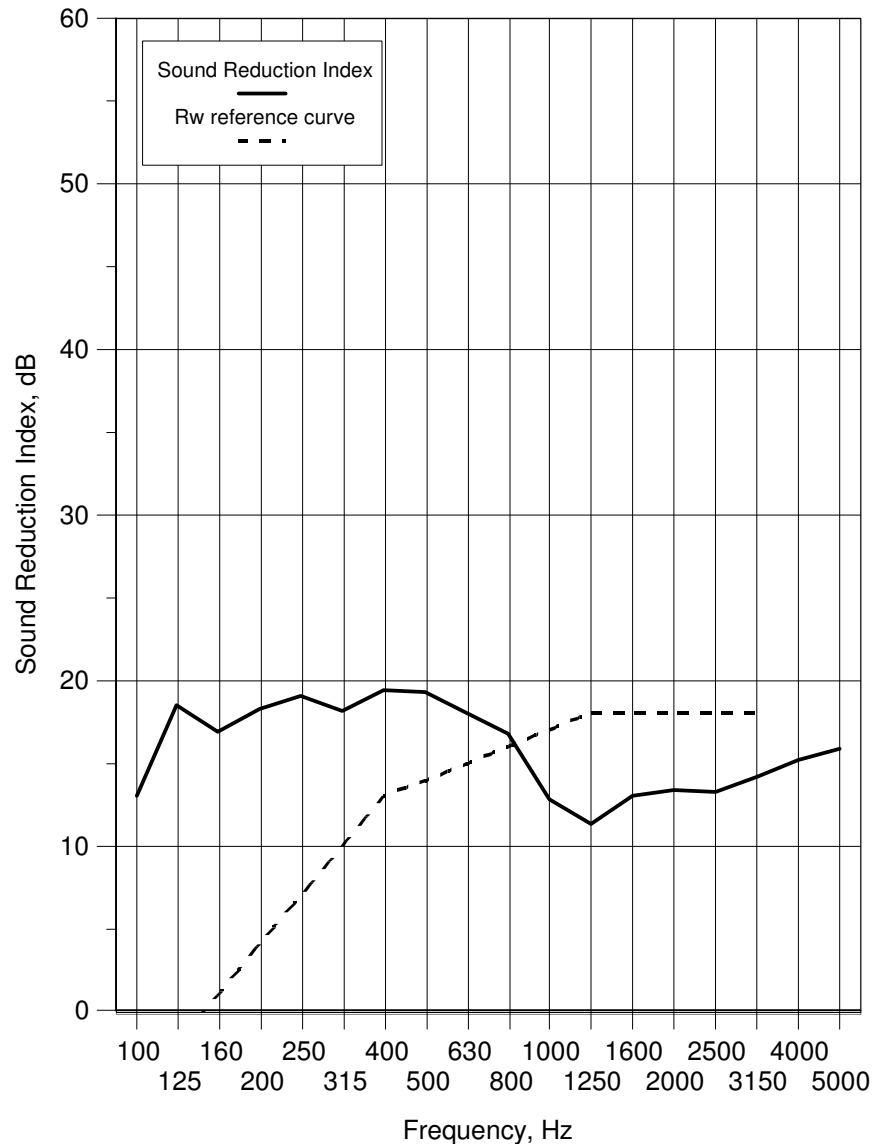

Rating according to BS EN ISO 717-1:2013

Rw(C;Ctr)= **14 (0; 0) dB**

* shows measurement corrected for background

+ shows frequency beyond standard and not UKAS accredited

Data Sheet 2

Test Number :	4	Test Room:	Source	Receiving
Client:	Sika Services AG	Air temperature:	12 °C	13.1 °C
Test Date:	23/12/2015	Air humidity:	73 %	74 %
Sample height:	1.2 m	Volume:	55 m3	300 m3
Sample width:	2 m			
Sample weight:	17 kg/m2	Air Pressure:	1013 mbar	
Product	Partition - Sealed with SikaHyflex-250 Facade sealant			
Identification:				

Freq f Hz	Sound Reduction Index, dB	
	1/3 Oct	1/1 Oct
50+	16.8	19.3
63+	23.0	
80+	20.3	
100	21.0	23.5
125	26.0	
160	25.4	
200	29.3	31.4
250	32.5	
315	33.4	
400	38.0	39.2
500	38.5	
630	42.1	
800	45.8	48.3
1000	49.4	
1250	51.4	
1600	53.4	51.3
2000	52.8	
2500	49.1	
3150	46.2	49.4
4000	50.6	
5000	56.9	
6300+	62.4 *	56.5
8000+	59.8 *	
10000+	52.9 *	
Average 100-3150	39.6	Version v2.1

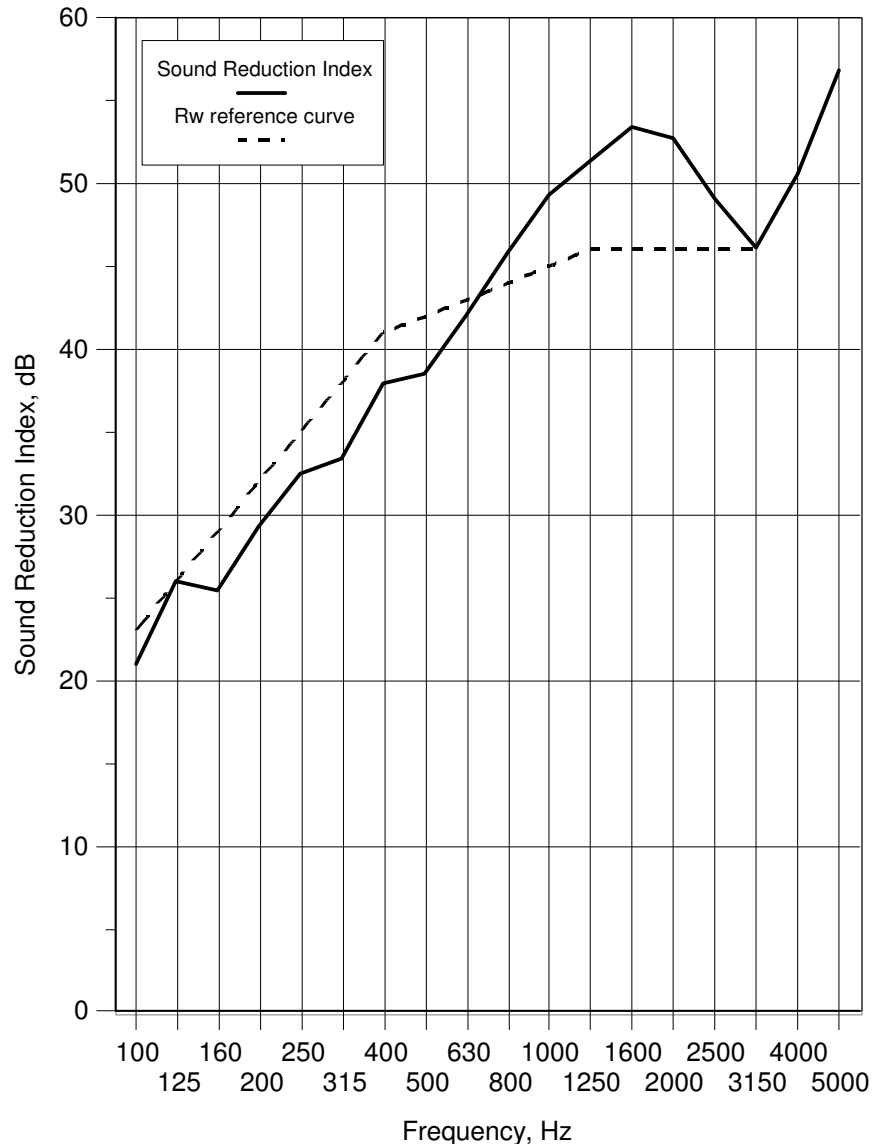

Rating according to BS EN ISO 717-1:2013

Rw(C;Ctr)= **42 (-1;-6) dB**

* shows measurement corrected for background

+ shows frequency beyond standard and not UKAS accredited

Drawing 1

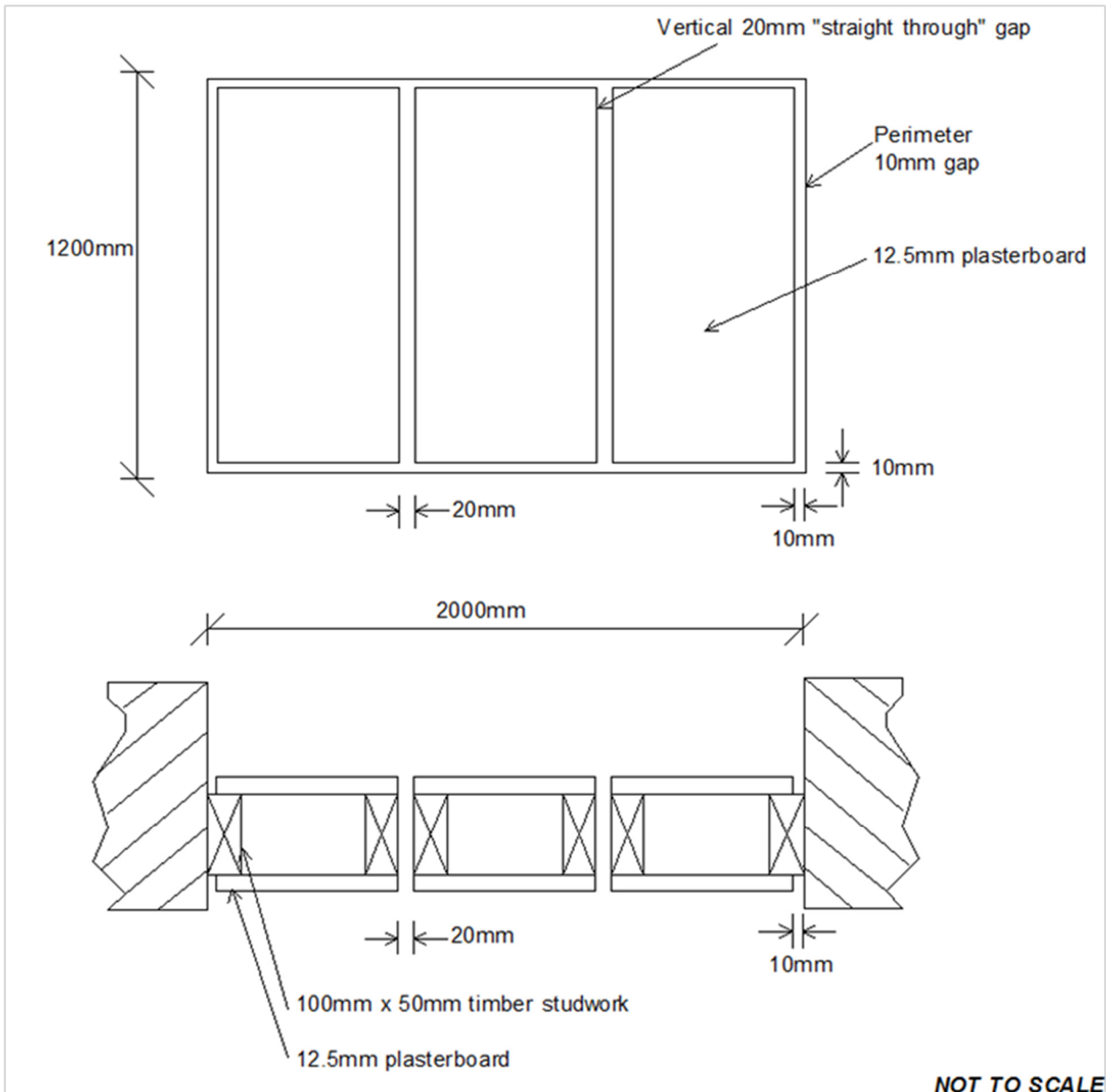

Drawing 2

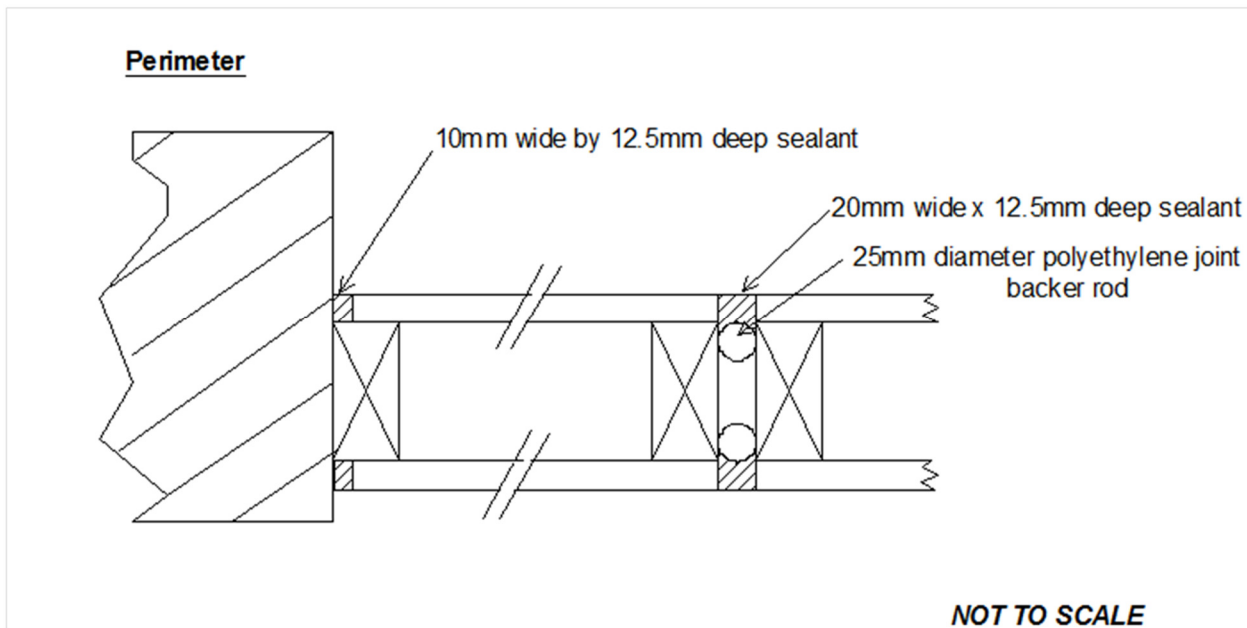

Appendix A – Test Procedure

Measurement of Sound Transmission in accordance with BS EN ISO 10140-2: 2010 – TP33

In the laboratory, airborne sound transmission is determined from the difference in sound pressure levels measured across a test sample installed between two reverberant rooms. The difference in measured sound pressure levels is corrected for the amount of absorption in the receiving room. The test is done under conditions which restrict the transmission of sound by paths other than directly through the sample. The source sound field is randomly incident on the sample.

The test sample is located and sealed in an aperture within the brick dividing wall between the two rectangular reverberant (i.e. acoustically "live") room, both of which are constructed from 215mm brick with reinforced concrete floors and roofs. The brick wall has dimensions of 4.8m wide x 3.1m high and 550mm nominal thickness and forms the whole of the common area between the two rooms.

One of the rooms is used as the receiving room and has a volume of 300 cubic metres. It is isolated from the surrounding structure and the adjoining room by the use of resilient mountings and seals ensuring good acoustic isolation. The adjoining source room has a volume of 115 cubic metres.

Broad band noise is produced in the source room from an electronic generator, power amplifier and loudspeaker. The resulting sound pressure levels in both rooms are sampled using a microphone mounted on an oscillating boom and connected to a real time analyser. The signal is filtered into one third octave band widths, integrated and averaged. The value obtained at each frequency is known as the average sound pressure level for either the source or the receiving room. The change in level across the test sample is termed the sound pressure level difference, i.e.

$$D = L_1 - L_2$$

where

- D is the equivalent Sound Pressure level difference in dB
- L₁ is the equivalent Sound Pressure level in the source room in dB
- L₂ is the equivalent Sound Pressure level in the receiving room in dB

The Sound Reduction Index (R), also known by the American terminology Sound

Transmission Loss, is defined as the number of decibels by which sound energy randomly incident on the test sample is reduced in transmitting through it and is given by the formula:

$$R = D + 10 \log_{10} \frac{S}{A} \dots \text{in decibels}$$

Where

S is the area of the sample

A is the total absorption in the receiving room

both dimensions being in consistent units

The Sound Reduction Index is an expression of the laboratory sound transmission performance of a particular element or construction. It is a function of the mass, thickness, sealing, method of mounting etc. and is independent of the overall area of the sample.

However, when an example of this construction is installed on site, the sound insulation obtained will depend upon its surface area, as well as the absorption in the receiving room. The larger the area the greater the sound energy transmitted. Also, the overall sound insulation is affected by the sound transmission through other building elements, some of which may have an inferior performance to the sample tested. In practice, therefore, the potential sound reduction index of a construction is not fully realised on site. Furthermore, the sound reduction index of a particular sample of that construction can only be measured accurately in a laboratory, because only under such controlled conditions can the sound transmission path be limited to the sample under test.

R_w , C and C_{tr} have been calculated in accordance with the relevant section of BS EN ISO 717-1:1997 from the results of laboratory tests carried out in accordance with BS EN ISO 10140-2:2010.

Appendix B – Measurement Uncertainty

Measurement Uncertainty BS EN ISO 10140-2: 2010 – TP33

The following values of uncertainty are based on a standard uncertainty multiplied by a coverage factor of $k = 2$, which provides a level of confidence of approximately 95%.

Frequency, Hz	Uncertainty, \pm dB
100	3.2
125	2.9
160	2.5
200	2.5
250	1.8
315	1.8
400	1.5
500	1.5
630	1.2
800	1.2
1000	1.2
1250	1.2
1600	1.2
2000	1.2
2500	1.2
3150	1.2

Sudbury Consultancy

Holbrook House
Little Waldingfield
Sudbury
Suffolk
CO10 0TF
Tel: +44 (0)1787 247595

Manchester Consultancy

Lynfield House
Church Street
Altrincham
Cheshire
WA14 4DZ
Tel: +44 (0)161 929 5585

London Consultancy

70 Cowcross Street
London
EC1M 6EJ
Tel: +44 (0)207 251 3585

Birmingham Consultancy

Cornwall Buildings
45 Newhall Street
Birmingham
B3 3QR
Tel: +44 (0)121 213 6342

South Africa Consultancy

Ground Floor, Liesbeek House
River Park
Gloucester Road
Mowbray
7700
South Africa
Tel: +27 (0)21 680 5305

Laboratory

Holbrook House
Little Waldingfield
Sudbury
Suffolk
CO10 0TF
Tel: +44 (0)1787 247595

Website: www.srltsl.com
e-mail: srl@srltsl.com

SRL offers services in:

Acoustics
Air Quality
Air Tightness
BREEAM
Compliance
Fire
Laboratory and Site Testing

Registered Name and Address:

SRL Technical Services Limited
Holbrook House
Little Waldingfield
Sudbury
Suffolk
CO10 0TF

Registered Number: 907694 England